

EINBAUANLEITUNG

ELEKTROKIT ANHÄNGERKUPPLUNG

INSTALLATION INSTRUCTION

ELECTRICAL KIT FOR TRAILER COUPLING

ISTRUZIONI DI MONTAGGIO

SEZIONE ELETROTECNICAL ACCOPPIAMENTO RIMORCHIO

NOTICE DE MONTAGE

KIT ELECTRIQUE DU DISPOSITIV DE REMARQUE

ARTIKEL-NR: 12400003J

D UNIVERSAL 7 POL
MIT KONTROLLEUCHE C2

GB UNIVERSAL 7 PIN
WITH CONTROL LAMP C2

I UNIVERSALI 7 POLI
CON LAMPADA SPIÀ C2

F UNIVERSEL 7 BORNES
AVEC LAMPE DE CONTRÔLE C2

INHALT

CONTENT

CONTENUTO

CONTENU

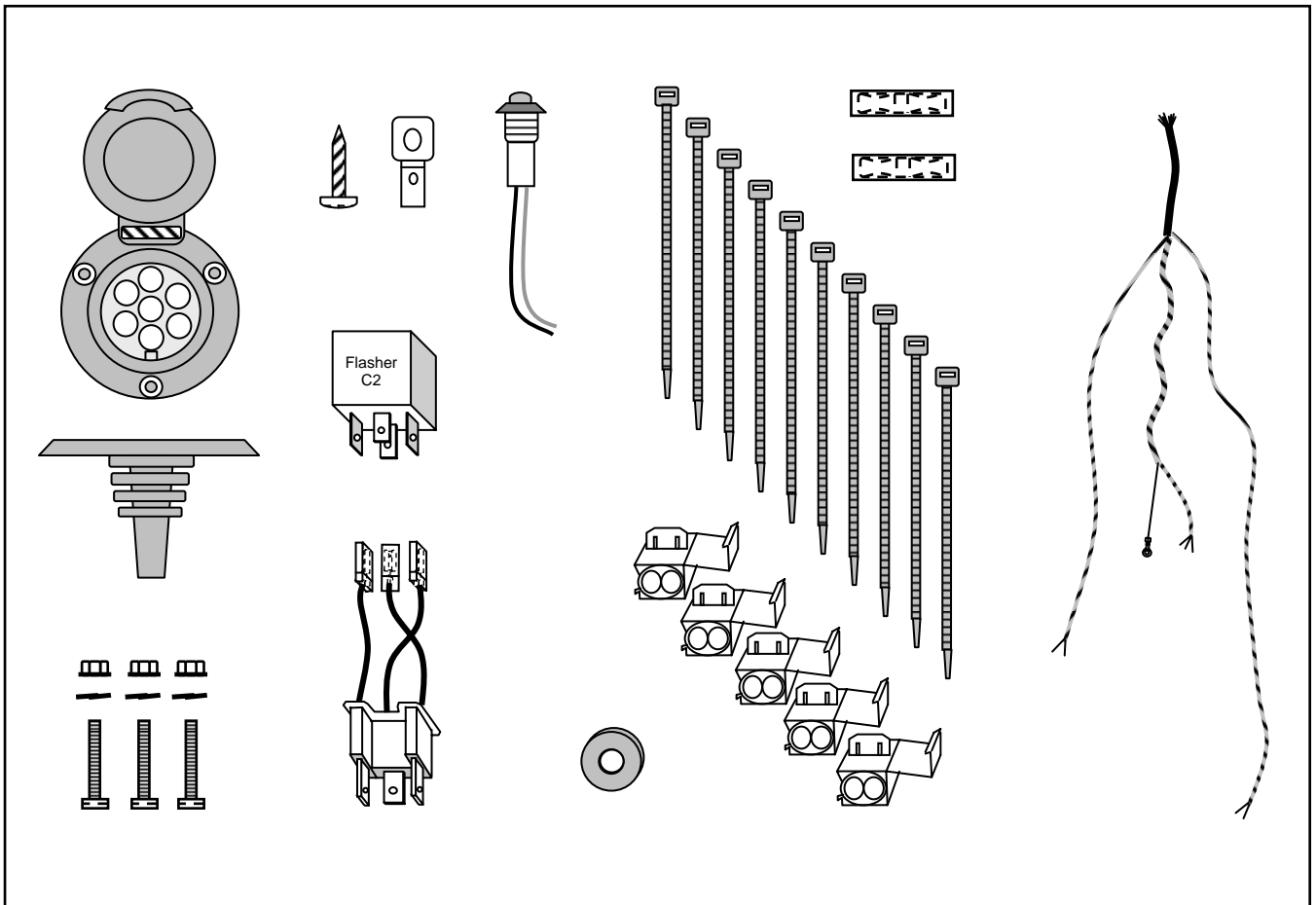

	D	GB	I	F
bl	blau	blue	blu	bleu
br	braun	brown	brun	bruno
ge	gelb	yellow	giallo	jaune
gn	grün	green	verde	vert
gr	grau	gray	grigio	gris
rt	rot	red	rosso	rouge
sw	schwarz	black	nero	noir
ws	weiss	white	bianco	blanc
L	links	left	a sinistra	à gauche
R	rechts	right	a destra	à droite

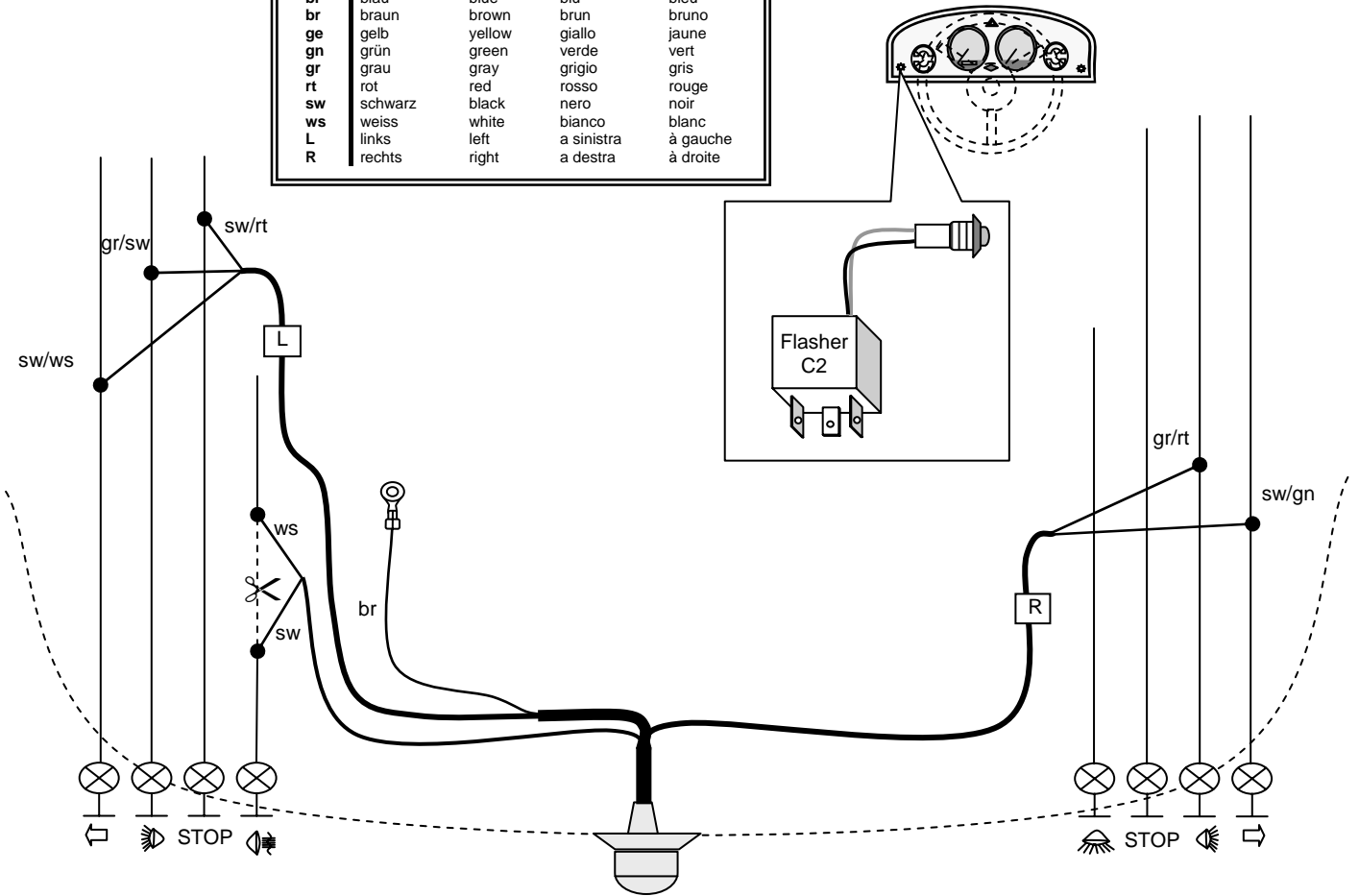

1.

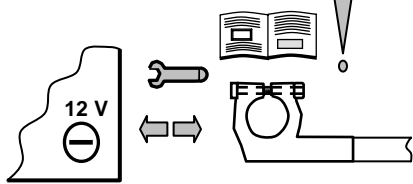

2.

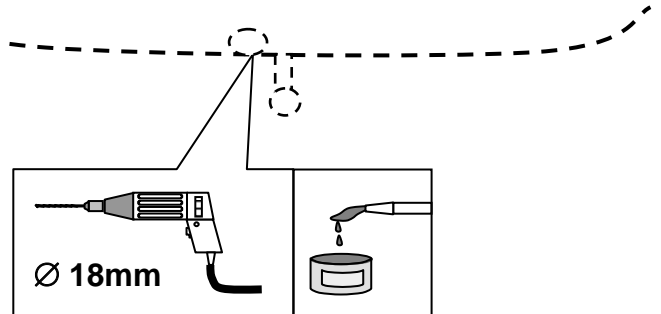

3.

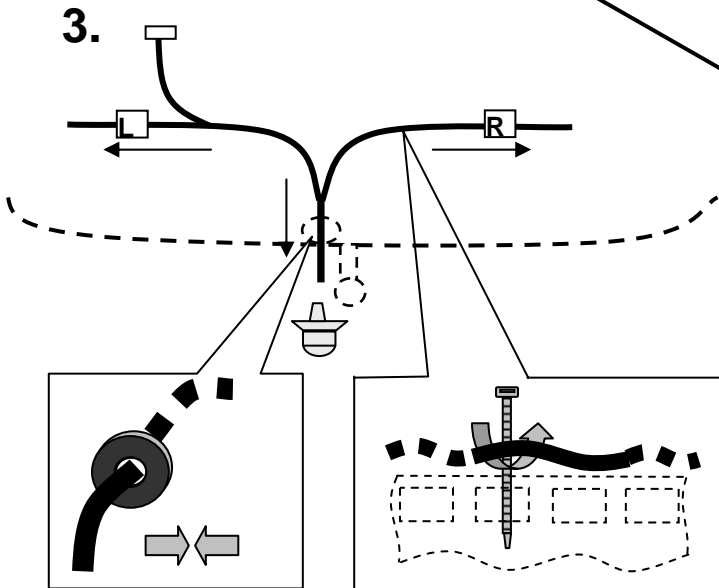

4.

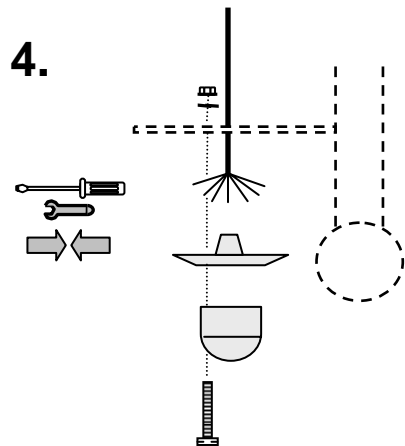

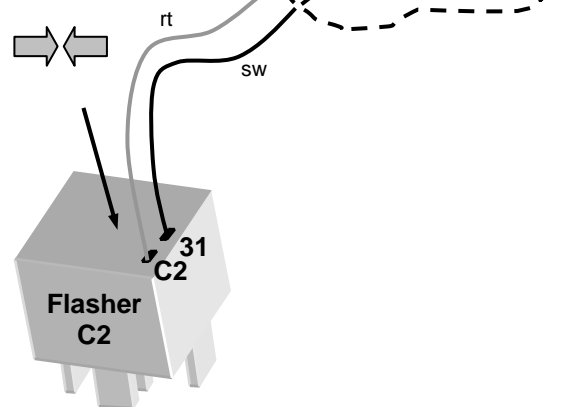
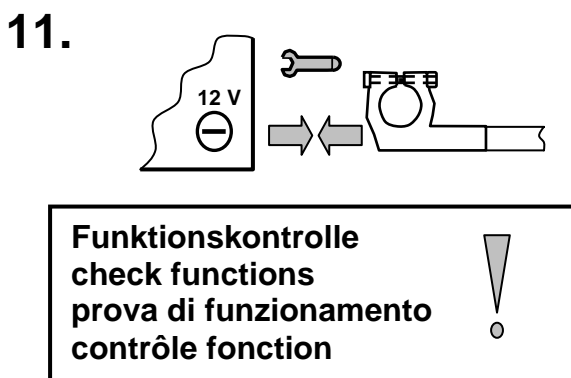
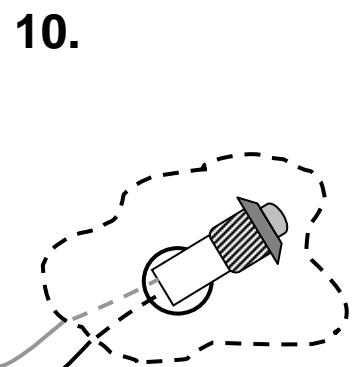
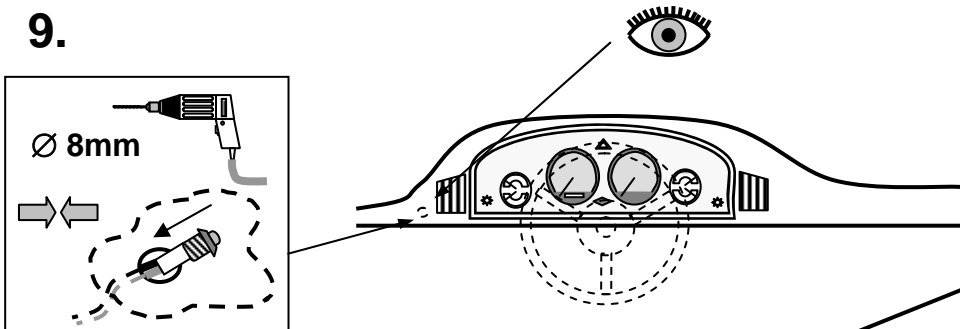
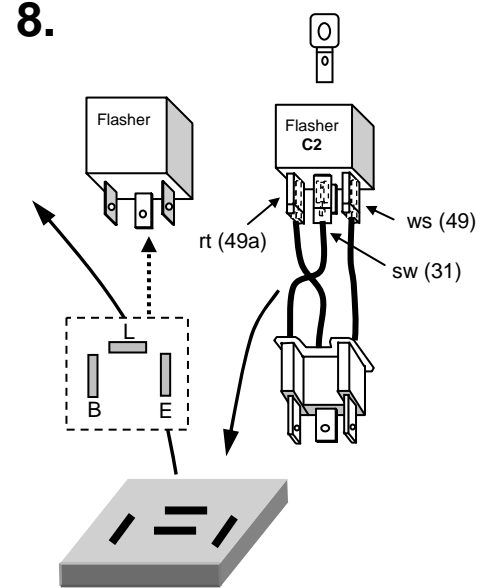
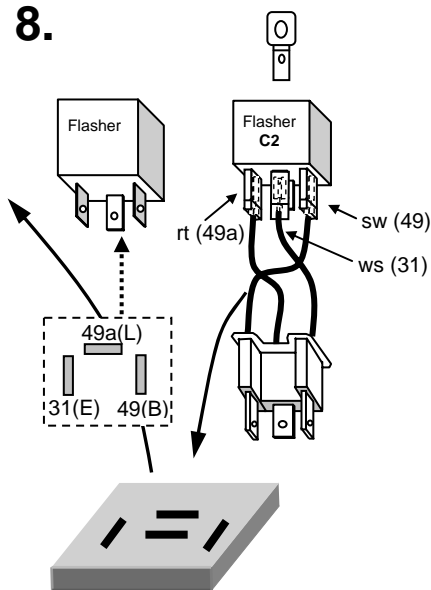
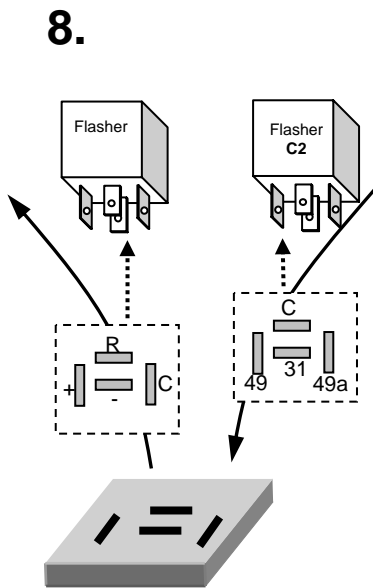
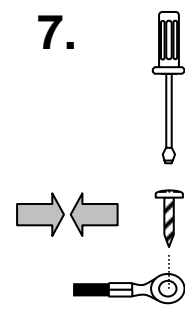
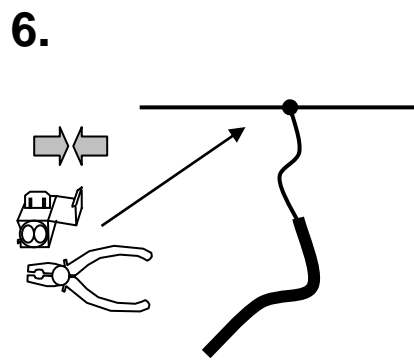
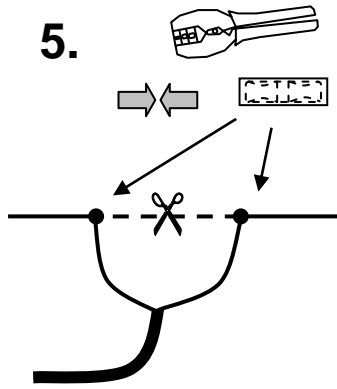

Kontaktbelegung 7 und 13 polige Steckdose
Connection diagramm 7 and 13-pin socket
Schema di connessione Presa 7 e 13 poli
Diagramme des connexions socle à 7 et 13 bornes

7P Kontakt contact contatto contact	13P Kontakt contact contatto contact	Stromkreis circuit circolazione elettrica circuit	Aderfarbe core colour colore cavo couleur de brin	
1/L	1	Fahrtrichtungsanzeiger links direction indicator left indicatore di direzione sinistro Indicateur de direction gauche	schwarz / weiss black / white nero / bianco noir / blanc	1,0 mm ²
2/54g	2	Nebelschlussleuchte Anhänger fog rear light retronebbia feu arrière de brouillard	weiss white bianco blanc	1,0 mm ²
3/31	3	Masse (für Kontakt-Nr. 1 – 8) earth (contact No. 1-8) massa isolata (per contatti 1-8) terre (contact 1-8)	braun brown bruno brun	1,5 mm ²
4/R	4	Fahrtrichtungsanzeiger rechts direction indicator right indicatore di direzione destro Indicateur de direction droite	schwarz / grün black / green nero / verde noir / vert	1,0 mm ²
5/58R	5	Schlussleuchte rechts right tail light luce posizione posteriore destra feu arrière droite	grau / rot gray / red grigio / rosso gris / rouge	1,0 mm ²
6/54	6	Bremsleuchte stop lights luci stop feux de stop	schwarz / rot black / red nero / rosso noir / rouge	1,0 mm ²
7/58L	7	Schlussleuchte links left tail light luce posizione posteriore sinistra feu arrière gauche	grau / schwarz gray / black grigio / nero gris / noir	1,0 mm ²
	8	Rückfahrleuchte reversing light luce retromarcia feu de recul	blau / rot blue / red blu / rosso bleu / rouge	1,0 mm ²
	9	Stromversorgung / Dauerplus power supply (battery plus) positivo da batteria alimentation (batterie plus)	rot red rosso rouge	2,5 mm ²
	10	Ladeleitung Plus charging circuit plus alimentazione sotto chiave circuit d'alimentation plus		
	11	Masse für Kontakt-Nr. 10 earth contact No. 10 massa per il contatto 10 (erre contact 10)		
	12	Steuerleitung Anhängererkennung trailer identification control line attacco ricono scimento rimorchio circuit d'identification de remarque		
	13	Masse für Kontakt-Nr. 9 earth (contact No. 9) massa (per il contatto 9) terre (contact 9)	rot / braun red / brown rosso / bruno rouge / brun	2,5 mm ²
8	2a	Nebelschlussleuchte Zugfahrzeug fog rear light on vehicle retronebbia automobibile feu arrière de brouillard à voiture	schwarz black nero noir	1,0 mm ²