

## FITTING INSTRUCTION

Clamp mark in acc. with		Cables joining
ISO	PN	
1	L	Left directional lights
2	+	Rear fog lights
3	31	Ground
4	R	Right directional lights
5	58R	Right side parking lights
6	54	Stoplights
7	58L	Left side parking lights

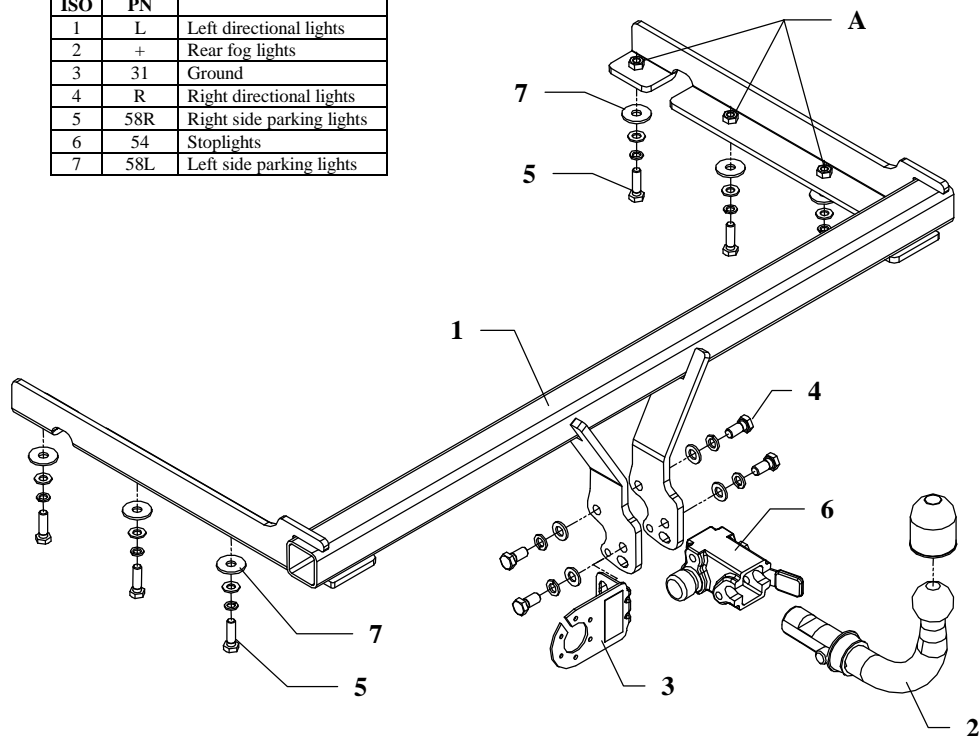

This towbar is designed to assembly in following cars:  
**HONDA STREAM 5 doors, VAN**, produced since 2001 till 2005,  
 catalogue number **Y26A** and is prepared to tow trailers max total weight  
**1400 kg** and max vertical load **60 kg**.

### *From manufacturer*

Thank you for buying our product. Their reliability has been confirmed in many tests. Reliability of towbar depends also on correct assembly and right operation. For this reasons we kindly ask to read carefully this instruction and apply to hints.

*The towbar should be install in points described by a car producer.*

## The instruction of the assembly

1. Disassemble the bumper, metal reinforcement (not used any more) and thermal shield.
2. Put main bar of the towbar to the chassis member in this way, so holes of the towbar (pos. A) agree with holes in members and fix using bolts M10x35mm (pos. 5).
3. Reassemble the bumper after cut out its fragment according to fig. 2.
4. Reassemble thermal shield.
5. Fix body of the automat (pos. 6) and the socket plate (pos. 3) using bolts M12x25mm (pos. 4) from accessories. Place tow-ball (pos. 2) according to supplied instruction.
6. Tighten all bolts according to the torque shown in the table.
7. Connect electric wires of 7-poles socket according to the instruction of the car. (Recommend to make at authorized service station).
8. Complete paint layer damaged during installation.

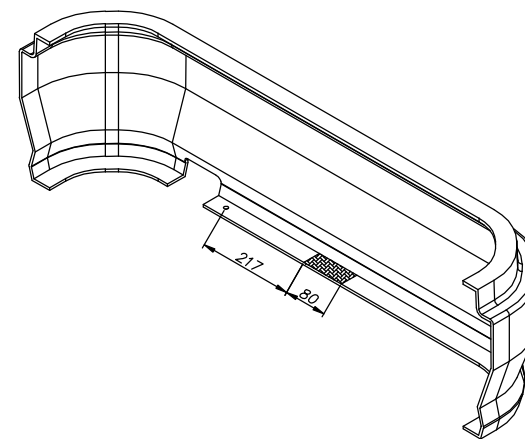

Fig. 2

Torque settings for nuts and bolts (8,8):

<b>M6</b> - 11 Nm	<b>M8</b> - 25 Nm	<b>M10</b> - 50 Nm
<b>M12</b> - 87 Nm	<b>M14</b> - 138 Nm	<b>M16</b> - 210 Nm









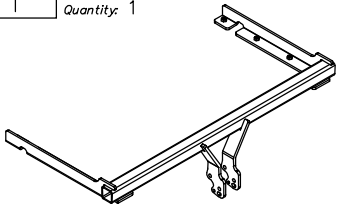

### NOTE

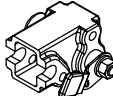
After install the towbar you should get adequate note in registration book (at authorised service station).The car should be equipped with:

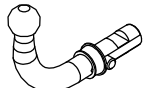
- Indicators
- Tow mirrors

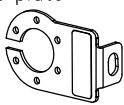
After 1000km of exploitation check all bolts. The ball of towbar must be always kept clear and conserve with a grease.

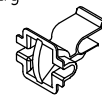
## Towbar accessories:

Pos. 1 Name: Main bar Quantity: 1 	Pos. 5 Name: Bolt 8,8 B Quantity: 6 Dim. : M10x35mm 	Pos. 10 Name: Spring washer Quantity: 4 Dim. : $\varnothing$ 12,2 mm 
	Pos. 6 Name: Body of the automat Quantity: 1 	Pos. 11 Name: Spring washer Quantity: 6 Dim. : $\varnothing$ 10,2 mm 
Pos. 2 Name: Tow ball Quantity: 1 	Pos. 7 Name: Washer Quantity: 6 Dim. : $\varnothing$ 35x $\varnothing$ 12x3mm 	Pos. 12 Name: Ball cover Quantity: 1 
Pos. 3 Name: Socket plate Quantity: 1 	Pos. 8 Name: Plain washer Quantity: 4 Dim. : $\varnothing$ 13 mm 	Pos. 13 Name: Body plug Quantity: 1 
Pos. 4 Name: Bolt 8,8 B Quantity: 4 Dim. : M12x25mm 	Pos. 9 Name: Plain washer Quantity: 6 Dim. : $\varnothing$ 10,5 mm 	



**PPUH AUTO-HAK S.J.**

Produkcja Zaczepów Kulowych  
Henryk & Zbigniew Nejman  
76-200 SŁUPSK ul. Słoneczna 16K  
tel/fax (059) 8-414-414; 8-414-413  
E-mail: [office@autohak.com.pl](mailto:office@autohak.com.pl)  
[www.autohak.com.pl](http://www.autohak.com.pl)

## Towing hitch (without electrical set)

Class: **A50-X** Cat. no. **Y26A**

Designed for:

Manufacturer: **HONDA**

Model: **STREAM**

Type: **5 doors, VAN**

produced since 2001 till 2005

Technical data:

**D-value: 8,2 kN**

maximum trailer weight: **1400 kg**

maximum vertical cup load: **60 kg**

**Approval number according to Directive 94/20/EC: e20\*94/20\*0560\*00**

## Foreword

This towbar is designed according to rules of safety traffic regulations. The towing hitch is a safety component and can be install only by qualified personnel. Any alteration or conversion of the towing hitch is prohibited and would lead to cancellation of design certification. Remove insulating compound and underseal from vehicle (if present) in the area of the matting surfaces of the towing hitch.

The vehicle manufacturer's specifications regarding trailer load and max. vertical cup load are decisive for driving whereat values for the towing hitch cannot be exceeded.

*D-value formula:*

$$\frac{\text{Max trailer weight [kg]} \times \text{Max vehicle weight [kg]}}{\text{Max trailer weight [kg]} + \text{Max vehicle weight [kg]}} \times \frac{9,81}{1000} = D \text{ [kN]}$$